

OWNER'S MANUAL

KidWalk

Dynamic Mobility System



Manufactured By

Prime Engineering

A Division of Axiom Industries, Inc.

4202 W. Sierra Madre Ave.
Fresno, CA 93722 USA

Toll-free: (800) 827-8263
Tel: (559) 276-0991
Fax: (800) 800-3355
E-Mail: info@primeengineering.com
Web Site: www.primeengineering.com

120107KWOM

TABLE OF CONTENTS

This owner's manual is organized into the following sections:

Description	Page No.
• Product Photo and Specifications	2
• Parts List	3
• Assembly Instructions	4
• Measurements & Initial Adjustments	7
• Initial Adjustments	8
• Positioning the Client	9
• Removing the Client	11
• Transport and Storage	11
• Safety Precautions & Maintenance	12
• Warranty	13

In addition, we have enclosed a number of *Notes* to assist in assembling and using the *KidWalk*. We want to do everything we possibly can to ensure the comfort and safety of every *KidWalk* client.

Each *KidWalk* has been pre-assembled, packed and shipped to allow for ease of assembly. If you have any questions or require further assistance, please contact your supplying dealer for assistance or contact us at 1-800-827-8263

Note: Carefully read all instructions and notes prior to assembly and use of the *KidWalk* .

SPECIFICATIONS

KidWalk



KidWalk is shown with optional Lateral Chest Support System and Headpad

Client Size: **24" to 48" tall**
Seat Height: **9" to 22" from the floor**
Weight Capacity: **65 lbs.**

Product Dimensions:

Base: 24" wide x 27" long
Overall Length: 32 1/2"
Standard Unit Weight: 40 lbs.
Casters: 4" Lighted
Mast Height: 33 1/2"
Upholstery: Black Nylon

PARTS LIST

KidWalk comes partially assembled in 1 carton.

The carton contains:

<u>Quantity</u>	<u>Description</u>
1	Base Assembly
1	Mast Assembly
2	Wheels
2*	Axles
2*	Axle Spacers

*Axles and axles spacers are in sealed poly bag

Optional Items:

Other optional items may be packed in the box and could include the Lateral Chest System, Headpad Assembly, Cruiser Wheel Assemblies or other components. Make sure to identify any optional components in the box and the instruction sheets that belong with them.

Component Identification

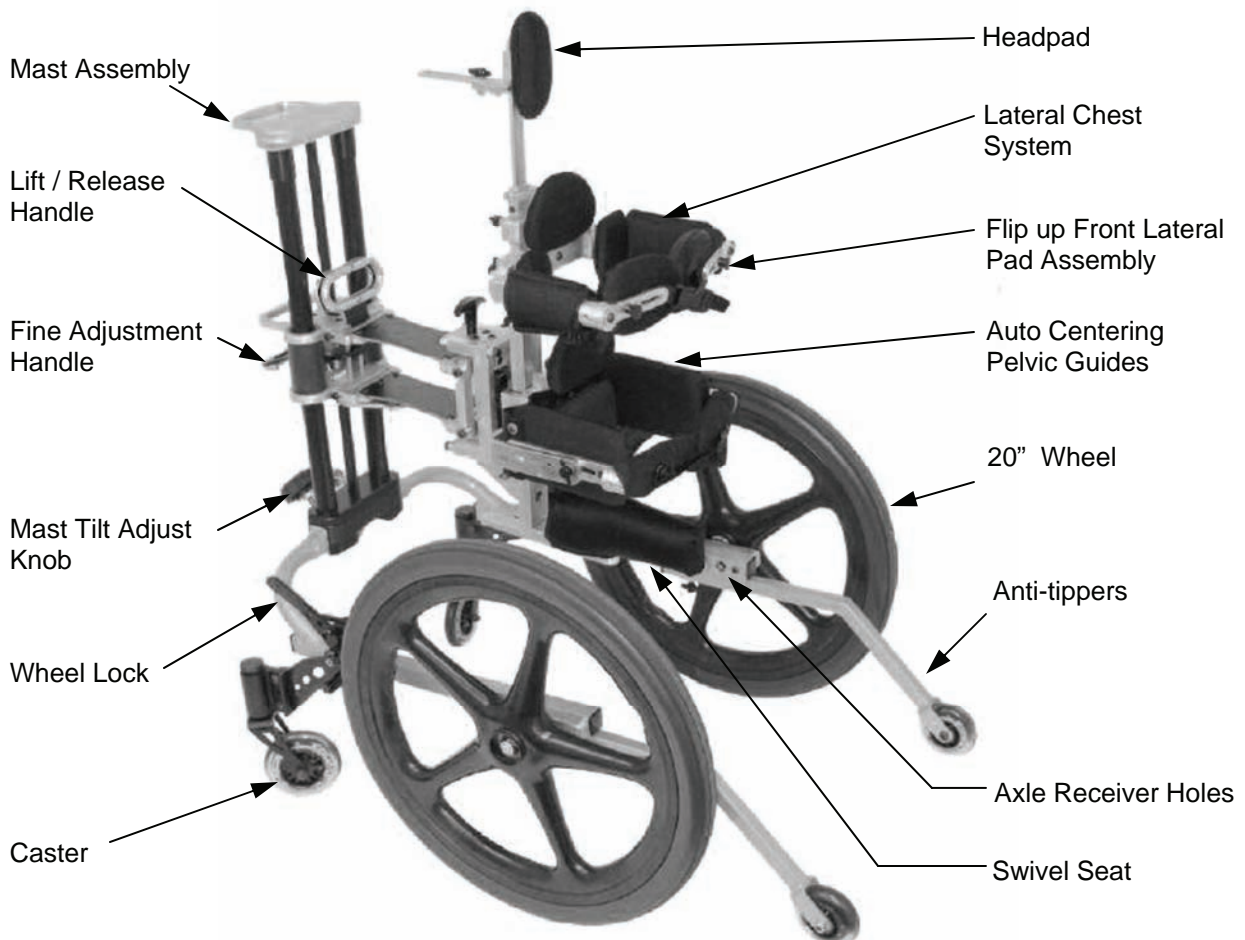

ASSEMBLY INSTRUCTIONS

Set-up and assembly on your *KidWalk* is easy when these directions are followed.



First:

Open carton, remove and identify the following assemblies and components.

- Base frame assembly with anti-tippers
- Mast assembly
- Wheels (2)
- Bag containing axles and spacers.
- Optional accessories (if ordered, e.g. Lateral Chest System, Headpad, Cruiser Wheels)

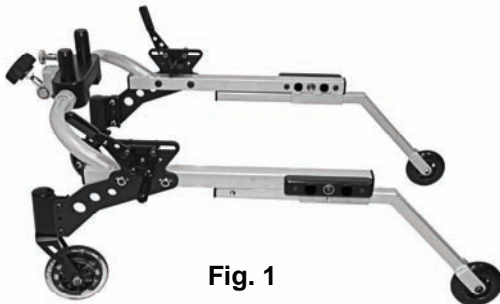

Fig. 1

Assembly Procedure:

- Place base frame on flat surface as shown in fig. 1.

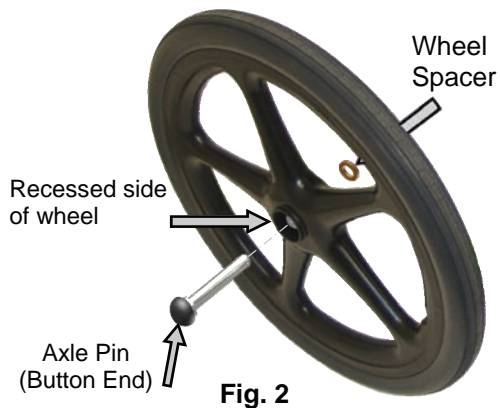

Fig. 2

- Remove axles and axles spacers from plastic bag. Insert an axle into a wheel from the recessed bearing side (fig. 2), push in button at end of axle to allow the axle to slide through the wheel bearings. Assemble 1 spacer onto axle at the back of the wheel while holding axle button in.

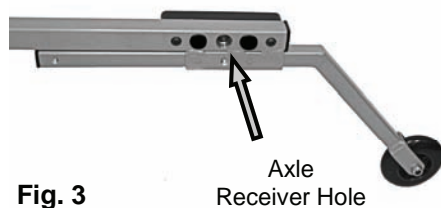

Fig. 3

Axle Receiver Hole

- Locate the axle receiver hole on either side of the base frame (fig. 3). Insert the axle, with wheel attached, into the center receiver hole until the axle button releases. Repeat procedure on opposite side.

Note: Always use center hole for initial setup.

ASSEMBLY INSTRUCTIONS

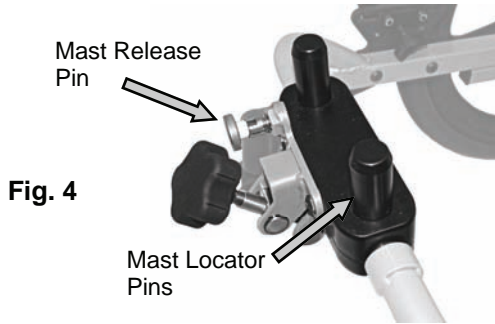

- Locate mast release pin on base frame (fig. 4). Pull pin outward and twist until pin is in the locked out position.

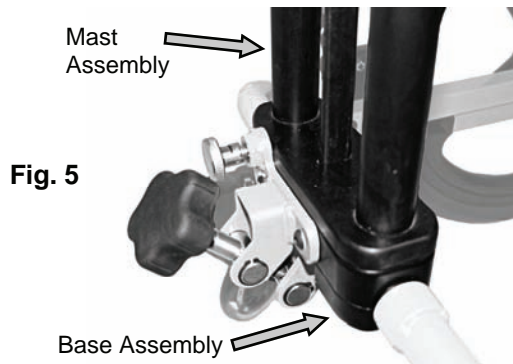

- Place mast assembly over locator pins on base assembly (fig. 5). **Rotate locking pin until it engages into mast assembly.** Ensure that the mast pin is fully engaged and holding the mast firmly to the base. If the mast lifts up from the base, twist the retaining pin again until it snaps into the mast.
- **Note: You must make sure that the mast is secured onto the base every time.**

Note:
KidWalk Must be used with it's Anti-Tippers at all times. Do NOT remove the Anti-Tippers from the unit or use it without them at any time.

Assembly for optional accessories:

Note: If you have other optional accessories that are not listed here, the instructions for their installation and use will be packed with the item.

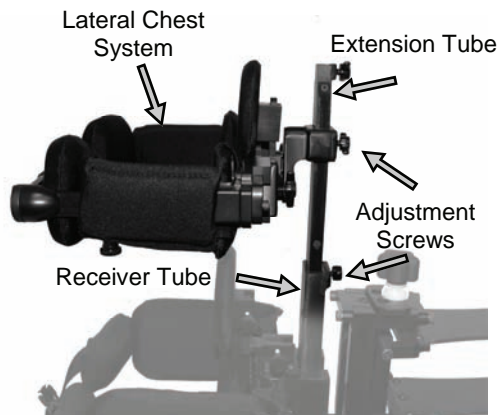

Fig. 6

Lateral Chest System

- Slide the Extension Tube through the Lateral Chest System Assembly (fig. 6).
- Slide the Extension Tube into the top of the Receiver Tube. Set pads at proper heights and tighten both adjustment screws (fig. 6)

ASSEMBLY INSTRUCTIONS

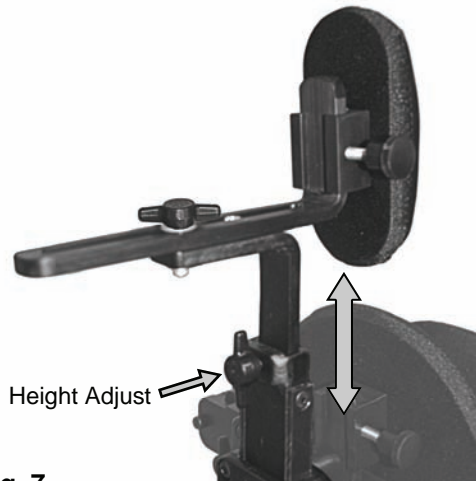

Fig. 7

Headpad

- Insert the Headpad into the extension tube with pad facing forward - tighten adjustment screw (fig. 7)

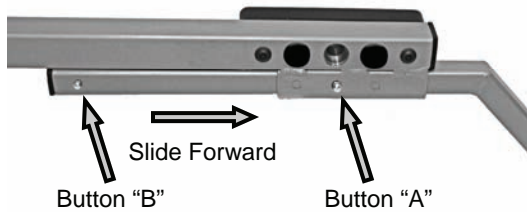

Fig. 8

Cruiser Wheels

- Remove the anti-tip levers from the base frame by depressing the position setting push button "A" (fig. 8) and sliding forward as far as possible. Press the retaining button "B" at the end of the anti-tip and slide completely out of the base frame.

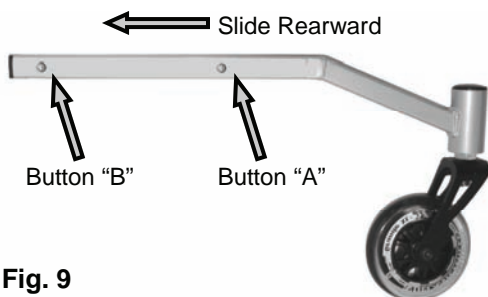

Fig. 9

- Press button "B" on the cruiser wheels and slide into frame receiver until it is through the receiver tube (fig. 9). Press button "A" and slide tube rearward until the button snaps into the center hole in frame receiver tube.

Note: KidWalk must be used with it's Anti-Tippers or Cruiser Wheels at all times. Make sure you replace the Anti-Tippers into the frame when not using the Cruiser Wheels.

MEASUREMENTS & INITIAL SETUP

Measurements:

The following measurements should be taken and recorded to properly setup the *KidWalk*:

- Inseam _____"
- Hip Width _____"
- Chest Width _____"
- Thoracic Height* _____"
- Head Height* _____"

*Thoracic height and head height measurements should be taken from the top of the inseam. These dimensions are needed to setup *KidWalk* optional Lateral Chest System and/or Headpad or Headrests.

KidWalk Initial Adjustments:

Seat Height

- Using the Lift/Release Handle or the Fine Adjustment Handle (fig. 10), adjust the seat height to 1" higher than the inseam measurement.
- To raise the seat assembly with the Lift/ Release Handle, press down on the top of the mast while lifting up on the Lift/ Release Handle.
- To raise the seat using the Fine Adjustment, place your hand in the handle and squeeze the Lower Fine Tune handle (fig. 10). Each time you squeeze the Fine Tune handle, the seat will rise up to 1/2 inch.
- To lower the seat assembly, simply press slightly downward on the Lift Release Handle (fig. 10). Minimal pressure is required to slide seat down the mast. **Do not push too hard.** Removing downward pressure from the Lift/Release Handle will stop the seat from lowering.

Lift / Release Handle

Fig. 10

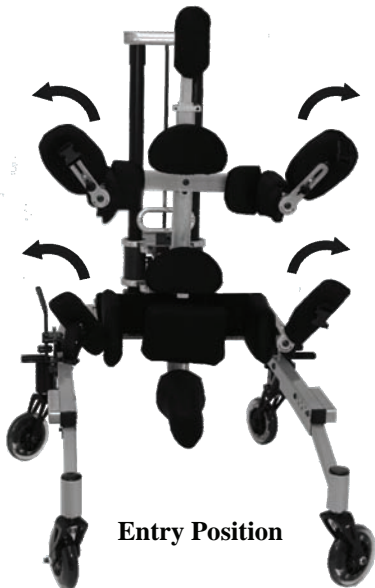
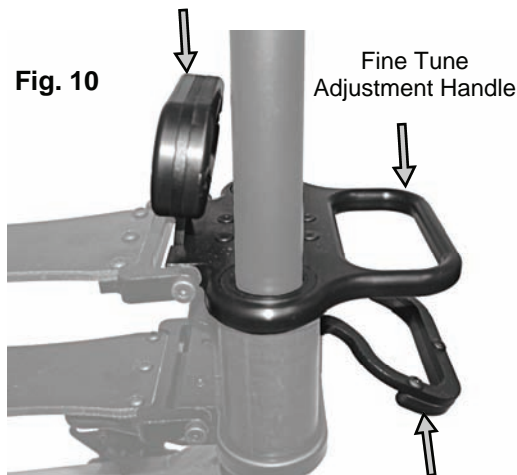

Entry Position

Other Items:

Make sure that any Lateral Supports are high enough and opened wide enough to allow the client to fit between them. Adjust any optional items to match the measurements for height and width per the instructions included with them.

NOTE: *Adjust all depth adjustable pads forward far enough to be able to fit the client into the unit when they are flipped down.*

KidWalk INITIAL ADJUSTMENTS

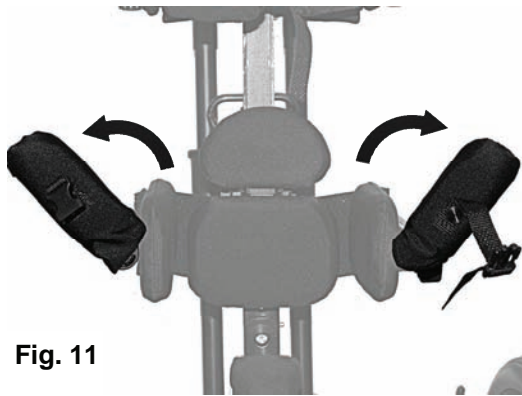

Fig. 11

Hip Supports

- Flip the front hip support pads upward and outward (fig. 11). If your *KidWalk* is equipped with upper Lateral Support Pads, flip them upward and outward as well.
- Set hip pad width to allow the client's hips to be easily placed between the hip pads by turning the knob located on the outside of the hip pad assembly (client's left side, fig. 13). Turning the knob clockwise makes the assembly wider while counterclockwise narrows the hip pad width.

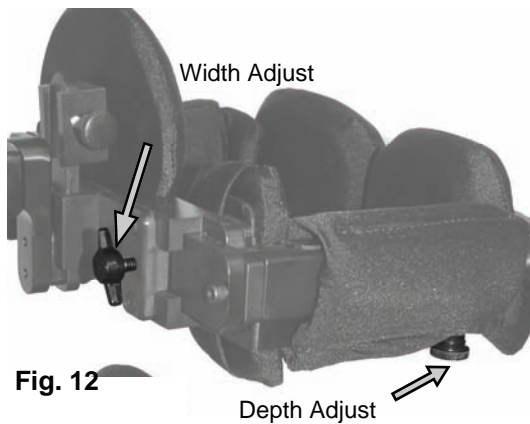

Fig. 12

Lateral Chest System (optional item)

- Loosen the knobs on the back side of the Upper Body Pads (fig. 12). Slide the pads outward enough to allow the client to fit between them (these pads will be re-adjusted after the client has been placed into the *KidWalk*).

NOTE: Slide all flip up pads forward to allow for client placement and tighten adjustment knobs to temporarily hold them in place.

Placing the client in the *KidWalk*

- Set the wheel locks.
- Place the client in the unit making sure to slide the client's hips as far back as possible into the *KidWalk*. Once the client is all the way back on the seat, flip the front pads down, then slide the front hip pads toward the client until they are snug and holding their hips in place. Tighten the depth adjustment knobs securely (fig. 13).

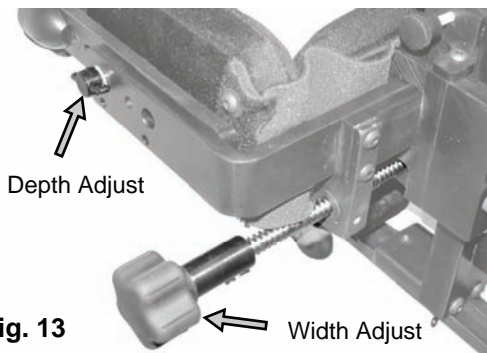

Fig. 13

Adjust the Hip Width

- Tighten the hip assembly with the width adjust knob as needed to get a snug fit at the client's hips.
- Snap the buckles together and pull strap snug (fig. 14).

Note: Position the client's hips back onto the seat as far as possible. The further back the client sits on the seat, the better.

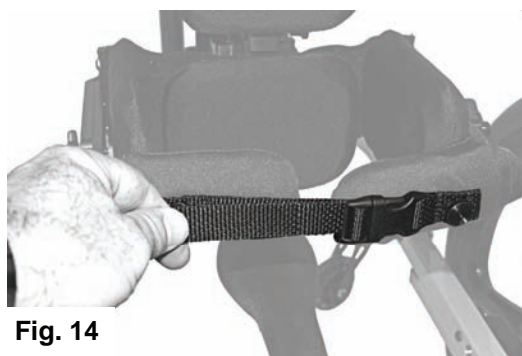

Fig. 14

INITIAL ADJUSTMENTS/POSITIONING THE CLIENT

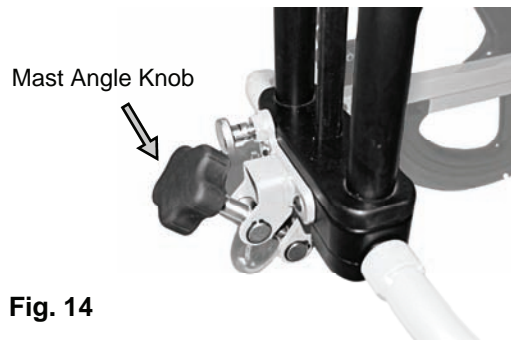

Fig. 14

Mast Angle (prompting)

Once the client has been placed in the *KidWalk* and all support surfaces are adjusted properly, it may be necessary to adjust the mast angle. The *KidWalk* provides forward and rearward prompting angle. Move the mast in small increments to assist in positioning the client or facilitate better gait.

- Turn the Mast Angle Knob (fig. 14) clockwise for more forward angle and counterclockwise for rearward angle.

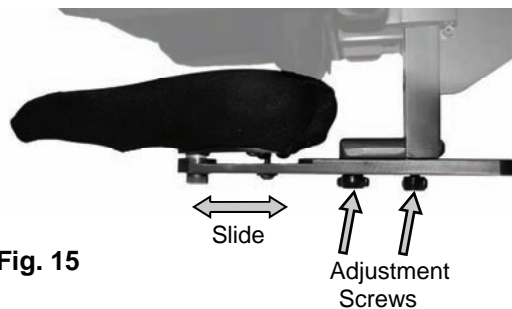

Fig. 15

Seat Depth Adjustment

- The seat has been pre-set at the factory to align with the center axle position on the frame. If it is necessary to alter the depth of the seat, loosen the two adjustment screws (fig. 15). Slide the seat forward or rearward as required and re-tighten screws.

Note: Make sure that both screws that hold the seat are secure.



Fig. 16

Changing Wheel Position

- There are three mounting positions for the large wheels. To move the wheels to a new location pull outward on the wheel while pressing the axle pin button (fig 16) to remove the wheel from the frame, While pressing the axle button, insert into new location. After locating the wheel, make sure that the axle has fully engaged and will not pull out.

Note: When moving the wheel on the frame, it will be necessary to move the wheel lock, (see "Changing Wheel Lock Position").

POSITIONING THE CLIENT

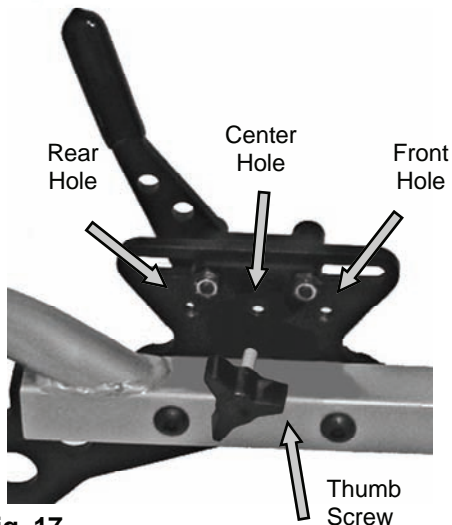

Fig. 17

Changing Wheel Lock Position

- The wheel lock is pre-set at the factory to the center wheel position. If you change the position of the large wheel, the wheel lock must be relocated as well.
- To change position of the wheel lock, remove the thumb screw (fig. 17). Move the wheel lock forward or rearward to coincide with the new wheel position. Align the threaded hole for the thumb screw with the front or rear hole (fig 17). Re-install thumb screw and tighten securely.

Note: Make sure the wheel locks are adjusted properly prior to use. Wheel locks must be properly adjusted to secure the large wheels at all times.

Optional Accessories:

Lateral Chest System

Height Adjustment

- Slide the Lateral Chest System up or down on the extension tube to desired height. Tighten height adjustment screw securely (fig. 18).

Width Adjustment

- Slide pads inward, making contact with the body in the desired upper body posture and tighten adjustment screws (fig. 18).

- Flip front lateral pads down, into place, snap the buckles together and pull straps snug.

Depth Adjustment

- Adjust the depth of the forward chest pads to hold the upper body firmly against the rear pads. (fig. 18).

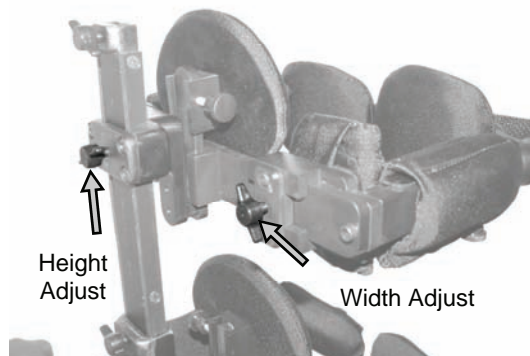

Fig. 18

Headpad

- Adjust Headpad height and depth to desired location and tighten the adjustment knobs (fig. 19).

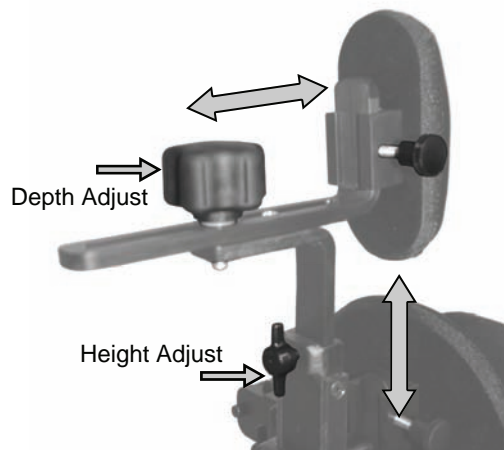

Fig. 19

REMOVING THE CLIENT TRANSPORT & STORAGE

Removing the client

To remove the client from the *KidWalk*:

- Set the wheel locks
- Squeeze the sides of the buckles at forward pads on hip assembly (and lateral chest system if applicable) to release (fig. 20).
- Rotate the forward pads upward and outward to allow clearance to exit.
- Remove any other restraint i.e.: Leg Wraps, Body Wraps, Leg Straps, if applicable.
- Lift client forward and off of seat.

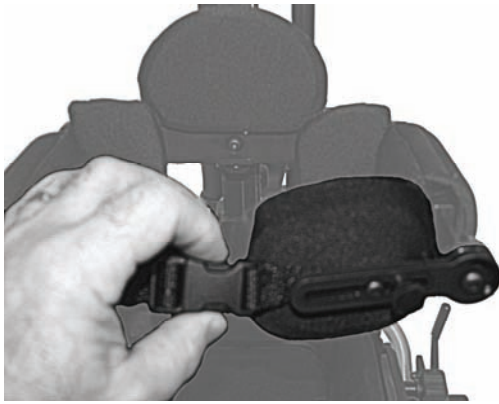
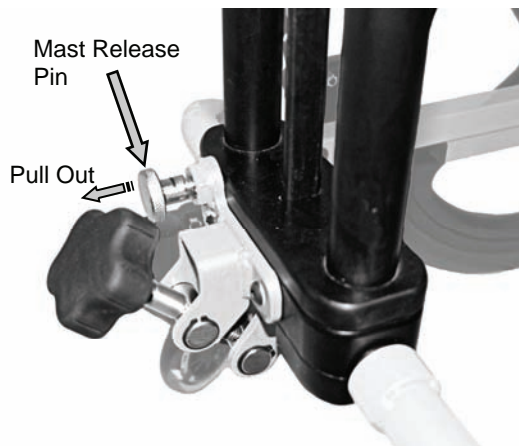

Fig. 20

Transport or Storage.

The *KidWalk* may be disassembled for ease of transport or storage.

- The mast may be removed by pulling outward on the release pin and rotating until it is in the lockout position. The mast can now be lifted off of the base assembly.
- If necessary, the large wheels may be removed by pressing inward on the axle pin button while pulling outward on the wheel.



NOTE: Make sure not to misplace the wheel spacers on the axle.

SAFETY PRECAUTIONS

CAUTION!

- Anti-tips must be properly adjusted with large wheels.
- Safety Straps must be fastened while client is in unit.
- Mast lock must be secure.
- Wheel locks must be properly adjusted with large wheels.
- All adjustment knobs must be secure.
- Do not over tighten hip width
- Never leave a client unattended while using the *KidWalk*.

Intended use

- Use on a level surface only.
- Maximum user weight limit - **65 lbs.**
- User height limits - **48" maximum**

General Maintenance

- Periodically ensure nuts and bolts are secured properly.
- Keep moving parts free of dirt and grime to allow for free movement.
- All fabrics should be hand washed with mild soap and water, then allowed to air dry.

LIMITED WARRANTY

Warranty coverage is extended to the original purchaser of the Prime Engineering product. This warranty is in effect for the **KidWalk Dynamic Mobility System**. Prime Engineering, Inc. ("the Company") shall repair or replace the Product that fails due to defect in material or workmanship per the following schedule:

Frames: 3 years to the original purchaser subject to the following terms, limitations and conditions.

Straps: One year to the original purchaser subject to the following terms, limitations and conditions.

Other Components: Upholstery, plastic parts, painted surfaces, rubber parts, bearings, casters and other parts not specifically identified above, all of which are warranted against defects in material and workmanship for three months from the original purchase date, subject to the following terms, limitations and conditions.

Warranty Conditions: This warranty shall be in effect from the original purchase date to the consumer. Any defective Product shall be delivered to *Prime Engineering*, or its local authorized dealer, at purchaser's expense for warranty inspection. You may contact Prime Engineering at (800) 827-8263 or authorized dealers in or near your location.

Limitations and Exclusions: The warranty provided shall not apply to (a) a serial numbered Product if the serial number has been removed or defaced; (b) any Product subjected to negligence, abuse, misuse, improper operation, maintenance, or storage, or damage beyond *Prime Engineering's* control, as determined by *Prime Engineering*, (c) defects arising from purchaser's failure to follow instructions. Any changes or additions to the Product of unauthorized parts not manufactured or furnished by *Prime Engineering*. The repair or replacement by *Prime Engineering* for a defective Part or Product shall be purchaser's sole and exclusive remedy under warranty. Repair labor/service charges are not covered by this warranty and are not the responsibility of *Prime Engineering*.

The foregoing Warranty is exclusive and in lieu of all other warranties, express, implied, or statutory, including warranties of merchantability and fitness for a particular purpose and design. In no event shall Prime Engineering be liable for any consequential or incidental damages.

Some states do not allow limitations on how long an implied warranty lasts to the exclusion or limitations of incidental or consequential damages, so the above limitations or exclusions may apply to you. This warranty gives you specific legal rights and you may also have other rights that vary from state to state.

Manufactured By

Prime Engineering

A Division of Axiom Industries, Inc.

4202 W. Sierra Madre Ave.
Fresno, CA 93722 USA

Tel: (559) 276-0991
Toll-free: (800) 827-8263
Fax: (800) 800-3355
E-Mail: info@primeengineering.com
Web Site: www.primeengineering.com

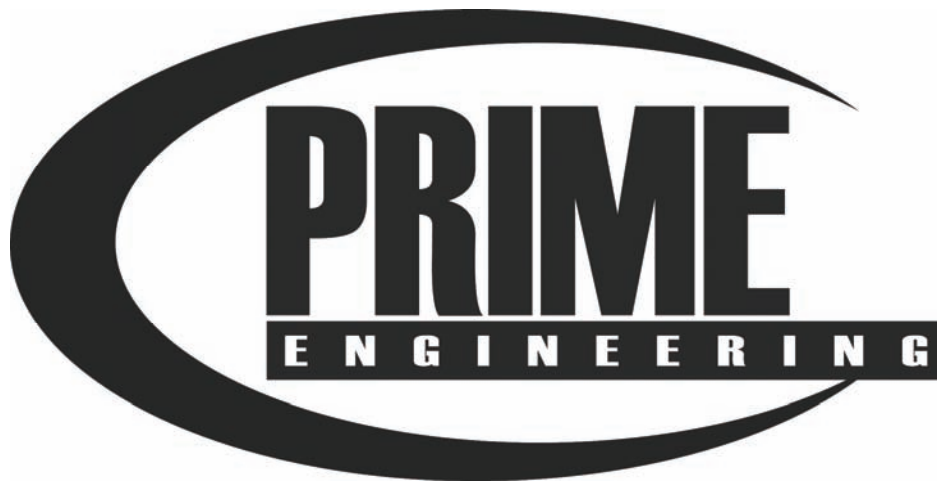

Prime Engineering

A Division of Axiom Industries, Inc.

4202 W. Sierra Madre Ave.
Fresno, CA 93722 USA

Toll-free: (800) 827-8263
Tel: (559) 276-0991
Fax: (800) 800-3355
E-Mail: info@primeengineering.com
Web Site: www.primeengineering.com